

 **OMEGA**<sup>®</sup>  
FOODTECH



**TF 32-TF 32/S**

# TF 32-TF 32/S TRITACARNE - MEAT MINCERS - FLEISCHWÖLFE - HACHOIRS - PICADORAS DE CARNE



## TRITACARNE DA BANCO 32/98

Carrozzeria, tramoggia, bocca, coclea, volantino, bacinella raccogli-carne (optional) in acciaio inox AISI 304.

TF 32: tramoggia fissa

TF 32/S: tramoggia rimovibile

Versione enterprise: 1 piastra inox e 1 coltello autoaffilanti, 1 estrattore.

Versione Unger S5 inox: Ø 98, 3 piastre, 2 coltelli, 2 anelli, 1 scatola di lame di ricambio ed 1 estrattore.

Per laboratori carni, supermercati e ristorazione collettiva.

Macchine conformi alle norme CE in materia di igiene e di sicurezza.

Comandi con dispositivo N.V.R.



## TABLE TOP MEAT MINCERS 32/98

Coating, feed pan, barrel, worm, locking ring and meat receiving tray (optional) made of stainless steel AISI 304.

TF 32: fixed feed pan

TF 32/S: removable feed pan

Enterprise version: 1 stainless steel holeplate and 1 self-sharpening knife, 1 extractor.

Unger version S5 stainless steel: barrel Ø 98, 3 holeplates, 2 knives, 2 rings, 1 box of spare blades and 1 extractor.

For meat processing plants, supermarkets and collective catering.

The machines complies with CE standards in terms of hygiene and safety.

Controls with N.V.R. device



## TISCH FLEISCHWÖLFE 32/98

Maschinengehaeuse, Einfüllschuessel, Schnecke, Schneckengehaeuse, Verschlussring, Empfangschale (optional) aus Edelstahl AISI 304.

TF 32: Fester Einfüllschüssel

TF 32/S: Abnehmbarer Einfüllschüssel

Enterprise Ausführung: 1 Lochscheibe und 1 Messer, 1 Ausziehvorrichtung.

Ausführung Unger S5 Inox: Schneidsatz Ø 98, 3 Lochscheiben,

2 Messer, 2 Einlege Ringe, 1 Schachtel Ersatzklingen und 1 Auszieher.

Für Fleischereien, Supermärkte und Großgastronomie.

Maschinen mit den CE-Normen in bezug auf Hygiene und Sicherheit konform.

Ein-Aus Drucktasten.



## HACHOIRS DE COMPTOIR 32/98

Carrosserie, trémie, bouche, vis sans fin, écrou, plateau de reception viande en acier inoxydable AISI 304.

TF 32: Trémie fixe

TF 32/S: Trémie amovible

Version Enterprise: 1 plaque et 1 couteau, 1 extracteur.

Version Unger S5 inox: bouche Ø 98, 3 plaques, 2 couteaux,

2 anneaux, 1 boîte de lames de rechange et 1 extracteur.

Pour laboratoires de boucherie, supermarchés et restauration collective.

Machines conformes aux normes CE en matière d'hygiène et sécurité.

Boutons Demarrage-Arrêt



## PICADORAS DE CARNE DE MESA 32/98

Carrocería de acero inoxidable AISI 304.

Boca, cóclea, volante y cubeta (opcional) de acero inoxidable.

TF 32: tolva fija

TF 32/S: tolva extraíble

Version Enterprise: 1 placa inoxidable, 1 cuchilla autoafilante y 1 extractor.

Version Unger S5 inoxidable: boca Ø 98, 3 placas, 2 cuchillas, 2 anillos, 1 caja de hojas de repuesto y 1 extractor.

Para talleres de elaboración de carnes, supermercados y restauración colectiva.

Máquinas conformes a lo establecido por las normativas CE en materia de higiene y de seguridad.

Mandos con dispositivo N.V.R.

## Specifiche tecniche / Technical specifications

	TF 32 TF 32/S
bocca, barrel, Schneidsatz, bouche, boca	32/98
motore, motor, Motor, moteur, motor	2,2 (3,0) kW (HP)
produzione, productivity, Leistung, productivité, productividad	400 kg/h
peso netto, net weight, Nettogewicht, poids net, peso neto	68 kg

**Optional:** connettore a 4 poli e porzionatrice PH A 4, connector 4 poles and hamburger attachment PH A 4, 4-Pol-Anschluss und Portioniergerät PH A 4, connecteur 4 pôles et reconstituteur de steak PH A 4, conector de 4 polos y porcionador PH A 4

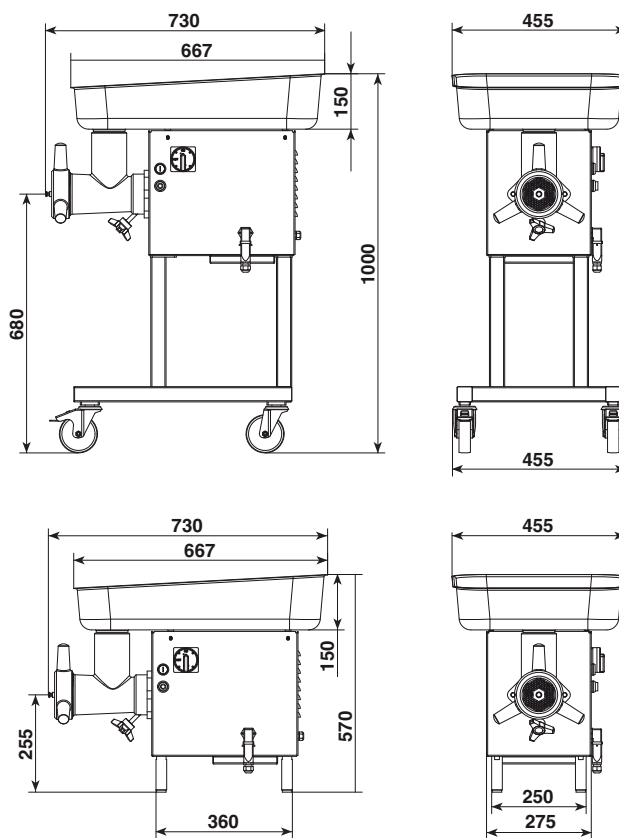

Nota: i dati del presente catalogo non sono impegnativi e potranno subire variazioni senza preavviso / Specifications and other features are subject to change without notice (04/10)